

BORDO I 0431A-M1

Designed by Kelvin Ng

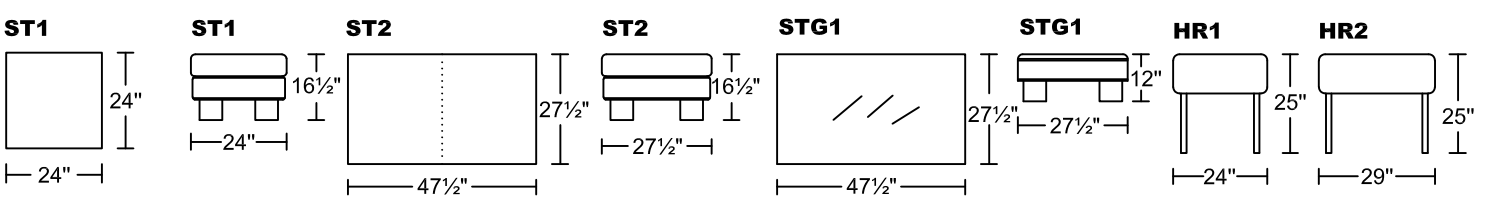
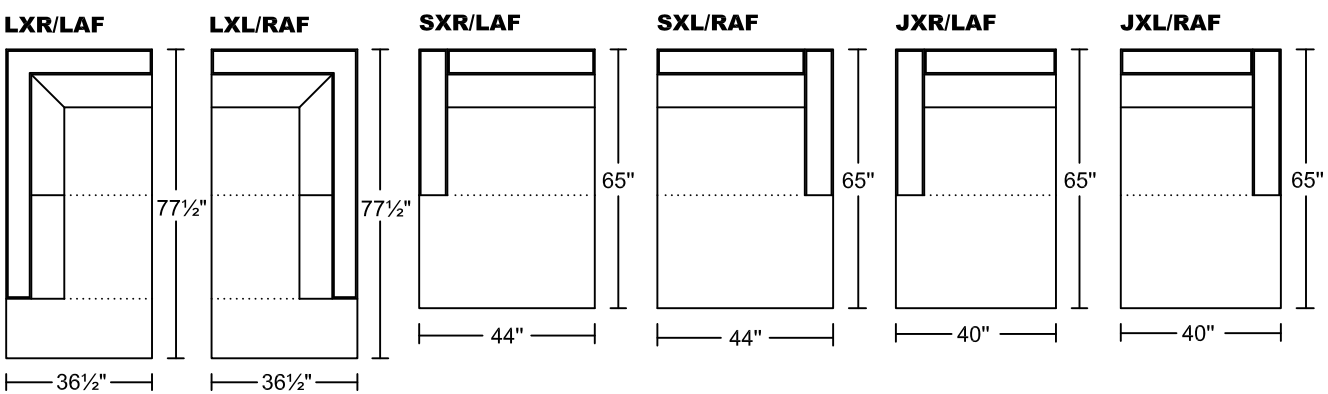
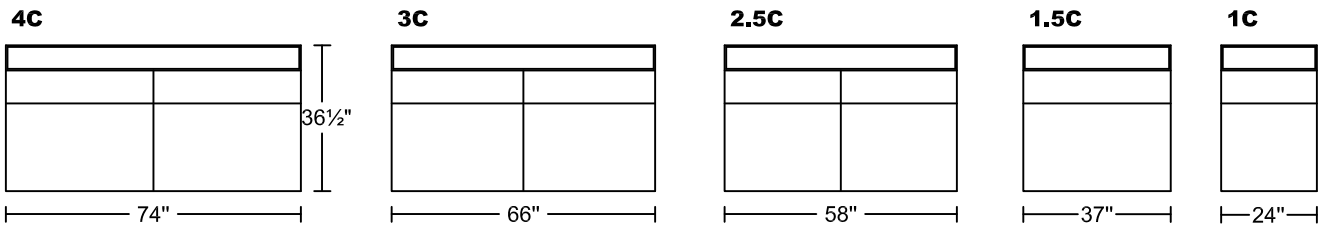
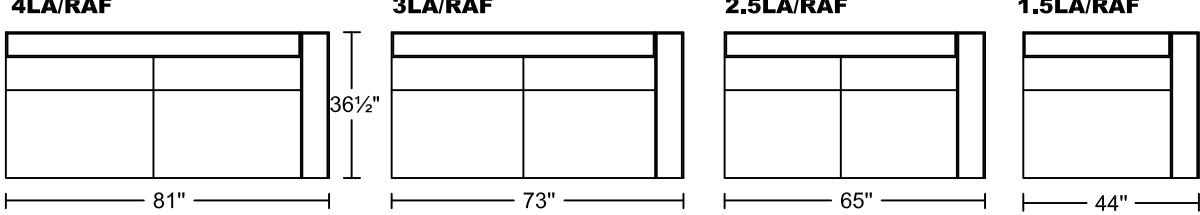
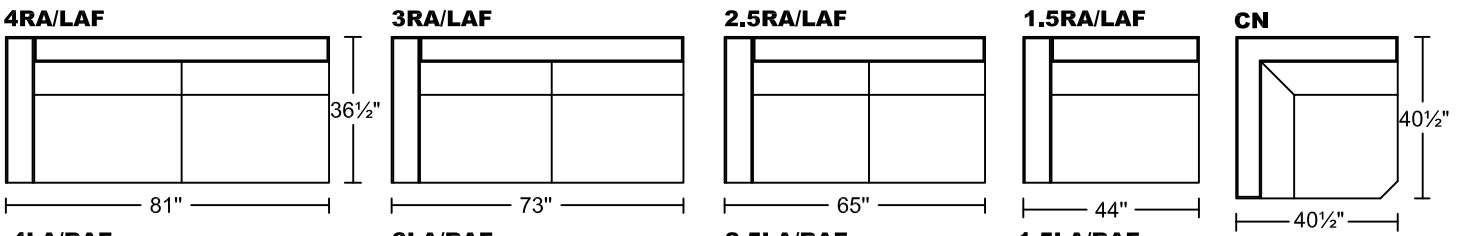
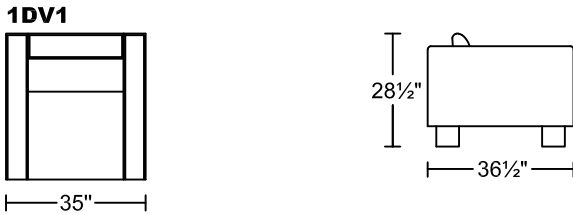
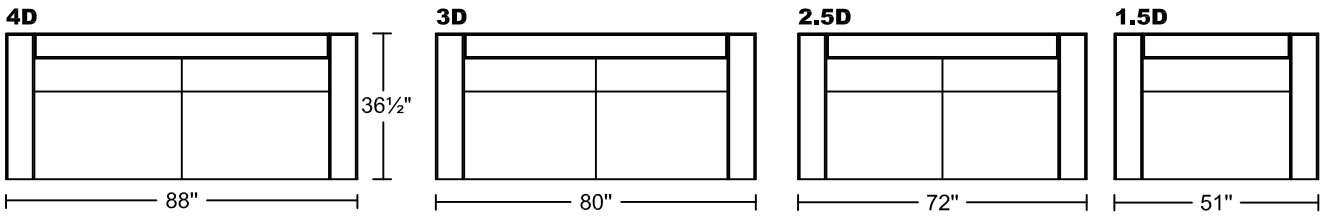

BORDO II 0431A-L1

Designed by Kelvin Ng

