

TUTTI II 0662B-M1

Designed by Kelvin Ng

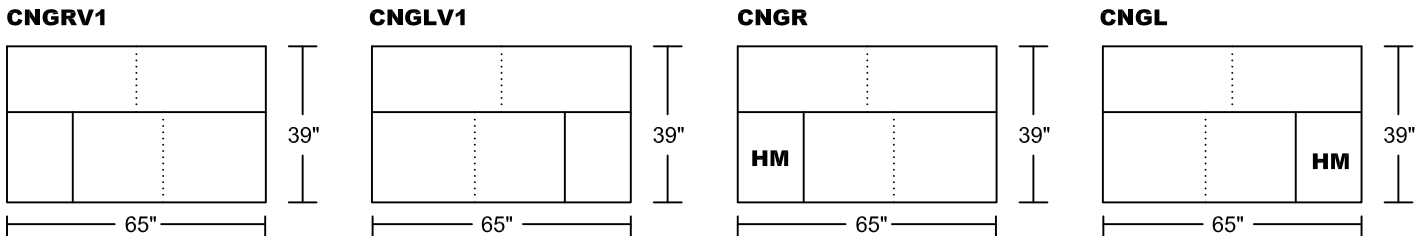
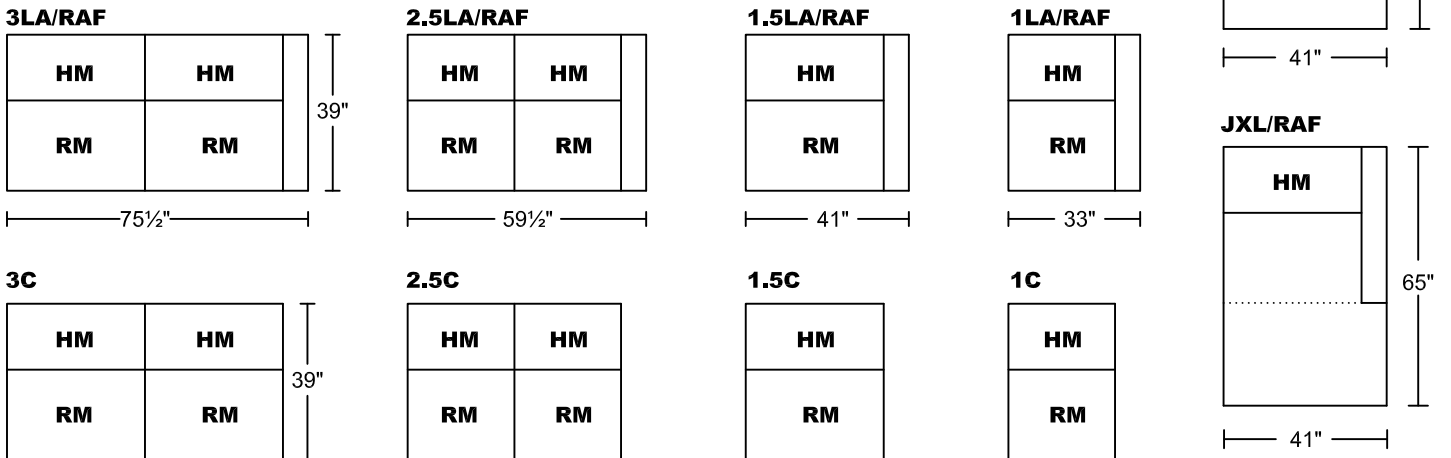
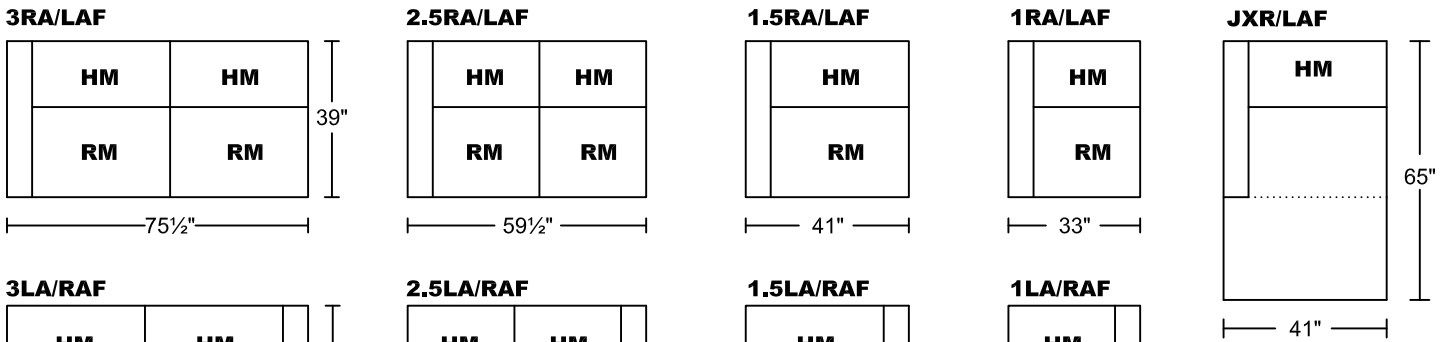
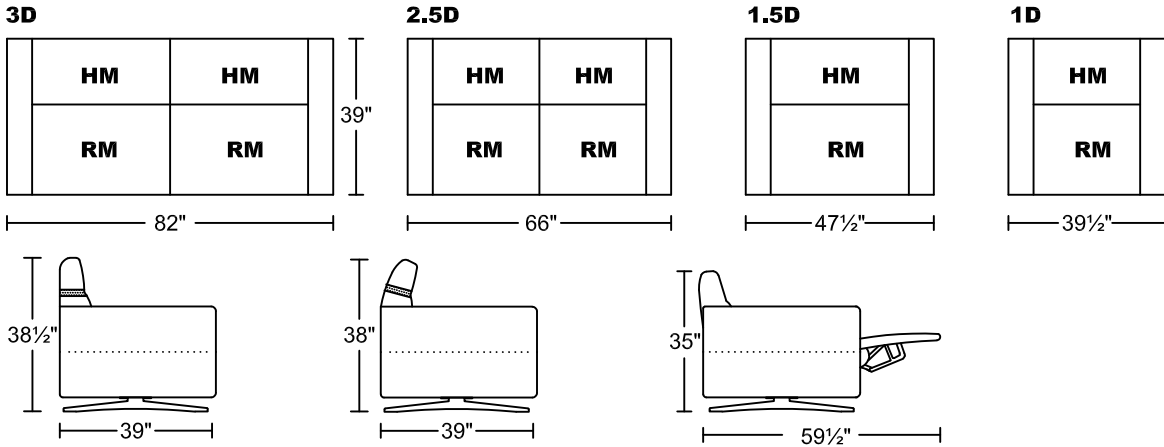

Remark:

HM - With Electrical Head Mechanism & Button Switch

RM - Reclining Mechanism

Seat Height: 18"

Seat Depth: 22.5"

Arm Height: 26"

TUTTI II 0662B-M1

Designed by Kelvin Ng

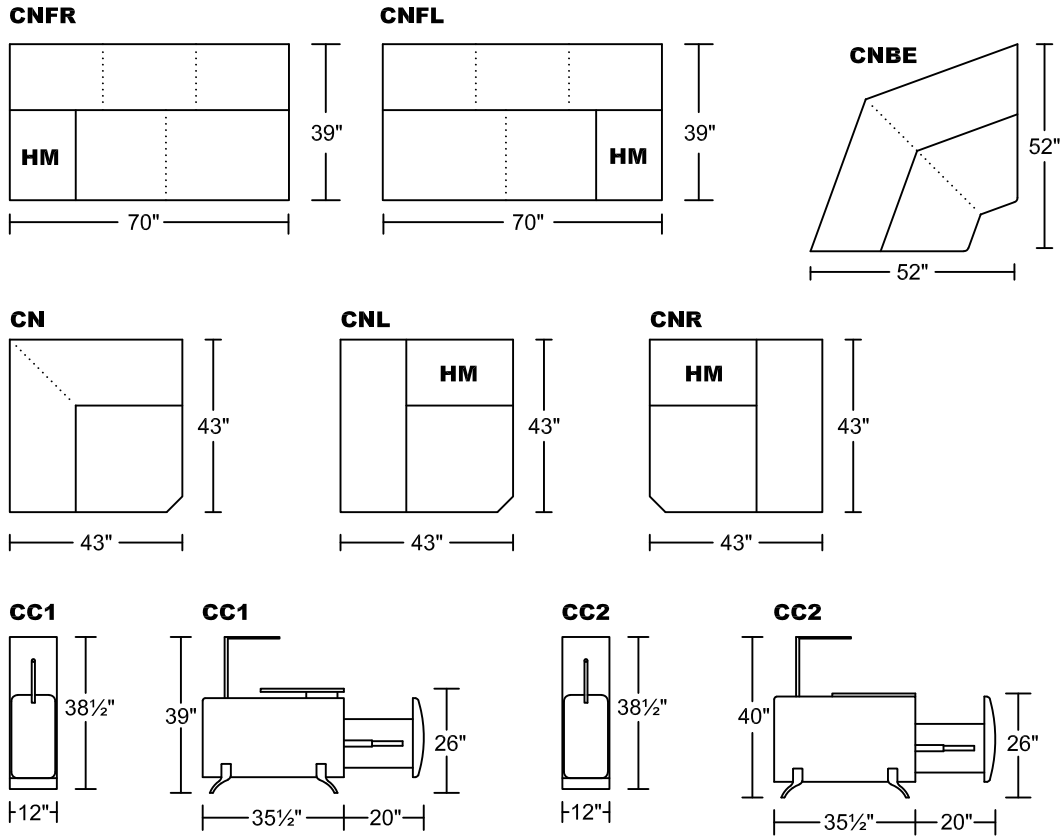

Remark:

HM - With Electrical Head Mechanism & Button Switch

RM - Reclining Mechanism

Seat Height: 18" Seat Depth: 22.5" Arm Height: 26"